

IMPLEMENTATION OF COMPACT SWITCHING POWER SUPPLY WITH HIGH POWER FACTOR

Marko Dimitrijević, Vančo Litovski
Faculty of Electronic Engineering Niš

Abstract: In this paper we will present a power supply – three phase AC/DC converter – with special requirements for power factor and dimensions. Development of such compact devices – up to 8cm³ – provides possibility for mass production of electronic subsystems intended to be implemented within the low voltage grid, reducing emission of higher harmonics (up to 40th) in the power grid and achieving maximal efficiency. Indirectly, this concept enables control of electric energy consumption of small loads. Development of power supply following these characteristics is significant for all producers of electronic equipment compatible with IEC-1000-3 standard.

Keywords: power supply, power factor

1. INTRODUCTION

Special requirements are related to power factor. The industry standards regulate the limits (minimum) of power factor. Switched-mode power supply (SMPS) with passive power factor correction (PFC) can achieve power factor of about 0.7 – 0.75, SMPS with active PFC – up to 0.99, while SMPS without any PFC has power factor of about 0.55 – 0.65 at the best. The current EU standard EN61000-3-2 appoints that all SMPS-es with output power more than 75W must include at least passive power factor correction.

The other requirements for power supply are nominal output voltage 5V, output current 400mA, three phase operation, input voltage range 90V_{RMS}-240V_{RMS}, possibility of only one phase operation, overvoltage protection and galvanic isolation. We will also consider development of the integrated circuit for power factor correction that will be mounted in SMPS with active power correction.

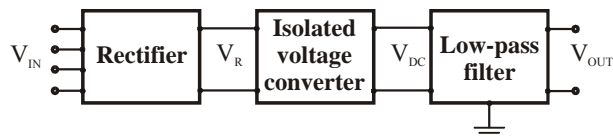

Figure 1. Power supply scheme

2. IMPLEMENTATION AND ELECTRICAL PROPERTIES

Power supply consists of three stages: three-phase full-wave rectifier, isolated voltage converter and output low-pass filter (Figure 1.).

The three-phase full-wave rectifier (Figure 2.) is implemented using high-voltage 1N4007 diodes D1-D16. The number of diodes is doubled to increase maximum input voltage. The neutral is connected symmetrically to phases, providing possibility of one phase operation, as well as normal operation with wrong neutral/phase connection. Rectified voltage V_R is limited to circa 400VDC by diodes D21, D22 (BZY97C200) and transistor Q1 (KSA1625).

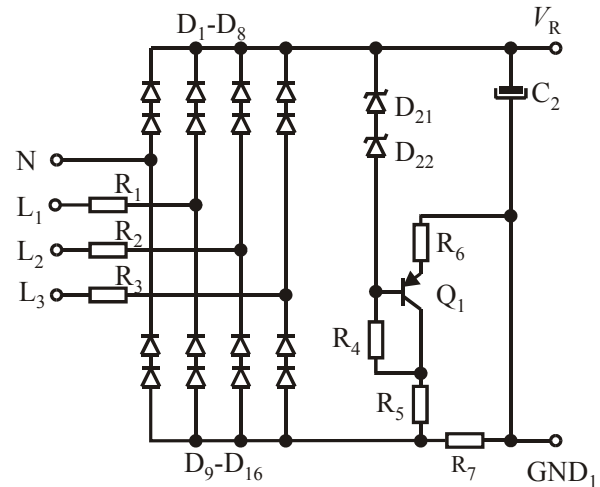

Figure 2. Full wave three-phase rectifier with protection circuit

Basically, there are several types of switched-mode power supplies that can be classified according to the circuit topology. Following the given requirements, the isolated flyback converter (Figure 3.) concept is used [1].

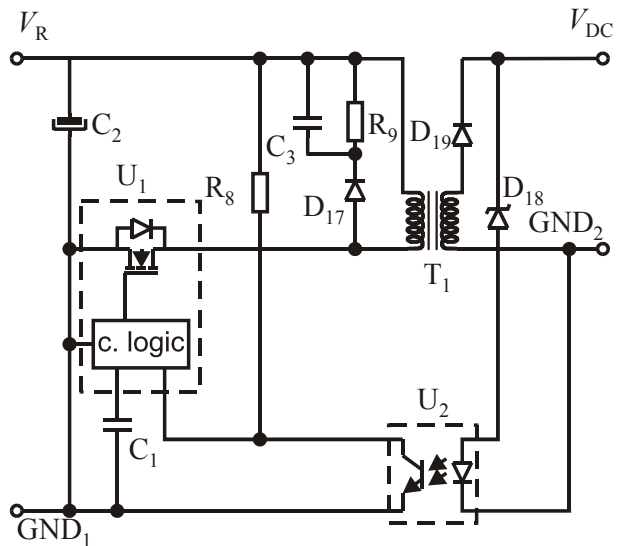

Figure 3. Voltage converter

Flyback converter is based on TNY267P integrated circuit (U1 on Fig. 3): a power MOSFET, oscillator, a high voltage switched current source, current limit and thermal shutdown circuitry are integrated onto a monolithic device. The start-up and operating power are derived directly from

the voltage on the MOSFET drain, eliminating the need for a bias winding and associated circuitry. This device also includes auto-restart, line undervoltage sense, and frequency jittering. The integrated auto-restart circuit safely limits output power during fault conditions such as output short circuit or open loop, reducing component count and secondary feedback circuitry cost. A line sense resistor R8 (1.5M Ω) externally programs a line under-voltage threshold, which eliminates power down glitches caused by the slow discharge of input capacitor C2 (4.7 μ F, 450V). The operating frequency of 132 kHz is jittered to significantly reduce both the quasi-peak and average electromagnetic interference, minimizing filtering cost. The integrated circuit breakdown voltage is 700V. C1 (0.1 μ F, 25V) is external bypass capacitor for the internally generated 5.8V supply. Additional circuit protection is performed by diode D17, connected to C3, R9.

During normal operation, switching of the power MOSFET is controlled by voltage driven from optocoupler U2 (L817B). MOSFET switching is terminated when the collector current is greater than 240 μ A. Full galvanic isolation is achieved using optocoupler U2 and transformer T1.

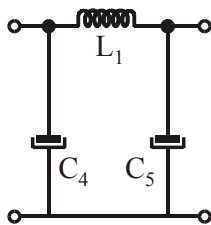

Figure 4. The low-pass filter

The low-pass output filter (fig. 4) is implemented using capacitors C4, C4 (220 μ F) and inductivity L1 (150 μ H).

Device implementation is shown on Figure 5.

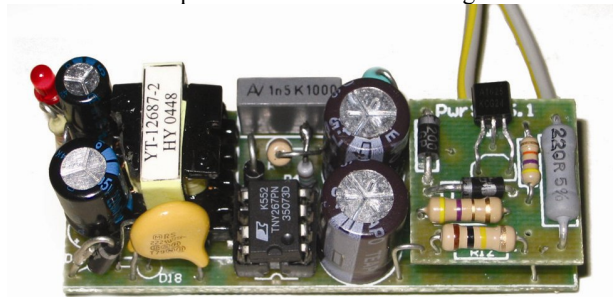

Figure 5. Device implementation

3. MEASUREMENT INSTRUMENTATION

The measurement of power factor and distortion usually requires special equipment. For example, a classical amperemeter will return incorrect results when attempting to measure the AC current drawn by a non-linear load and then calculate the power factor. A true RMS multimeter must be used to measure the actual RMS currents and voltages and

apparent power. To measure the real power or reactive power, a wattmeter designed to properly work with non-sinusoidal currents must be also used.

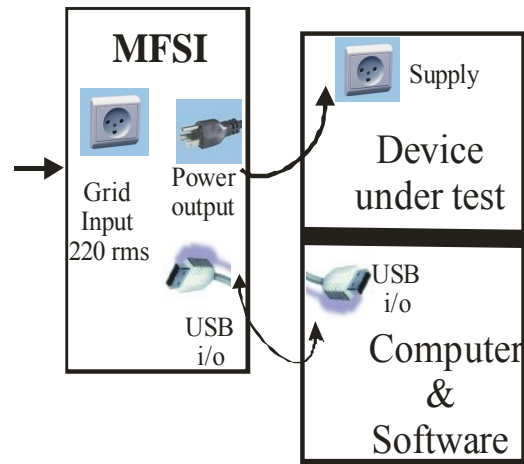

Figure 6. System for power factor and distortion measurement (denoted as MFSI)

Computer-based acquisition modules and software provide possibility of creation of simple and non-expensive methods and virtual instruments for power factor measurement and distortion characterization up to 40th harmonic of small loads and bring all advantages of virtual instrumentation [2,3] (Figure 6.). Figure 7. shows virtual instrument implemented in LabVIEW developing environment, which is used for distortion characterization and power factor measurements. Data acquisition is performed using an acquisition module. The system for power factor and distortion measurement is based on National Instruments NI USB-9215A acquisition module (DAQ). The data acquisition module has four channels of simultaneously sampled voltage inputs with 16-bit accuracy, 100kSmp/l per channel sampling rate and 250V_{RMS} channel-to-earth isolation, adequate for voltage measurements up to 40th harmonic (2 kHz). It also provides portability and hot-plug connectivity via USB interface.

Interface to acquisition module is implemented as device driver. USB-9215A module is supported by NIDAQmx drivers. All the measurements are performed using virtual channels. A virtual channel is collection of property settings that can include name, a physical channel, input terminal connections, the type of measurement or generation, and scaling information. A physical channel is a terminal or pin at which an analogue signal can be measured or generated. Virtual channels can be configured globally at the operating system level, or using application interface in the program. Every physical channel on a device has a unique name.

The user interface of the virtual instrument consists of visual indicators (Figure 8). It provides basic functions for measurement. The indicators – gauges and graphs – show measured values. All measured values are placed in a table, and after the measurement process in appropriate file.

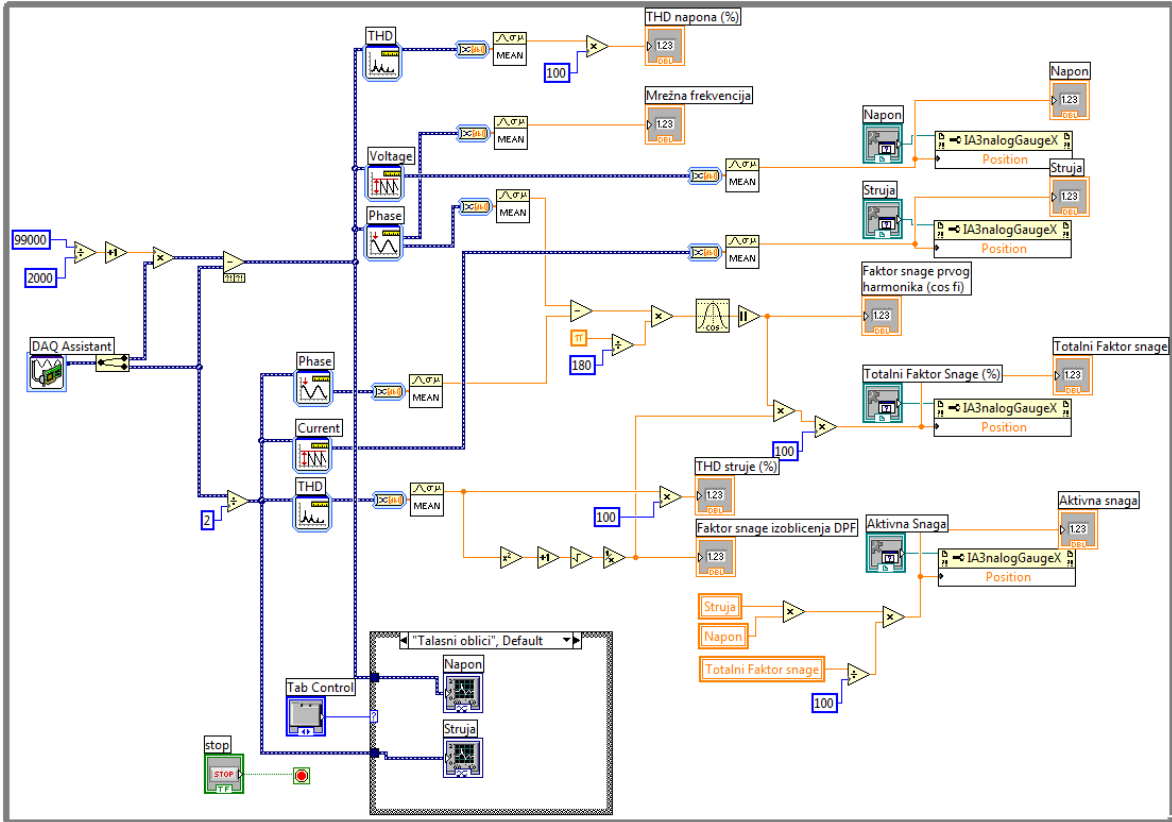

Figure 7. Virtual instrument implemented in LabVIEW

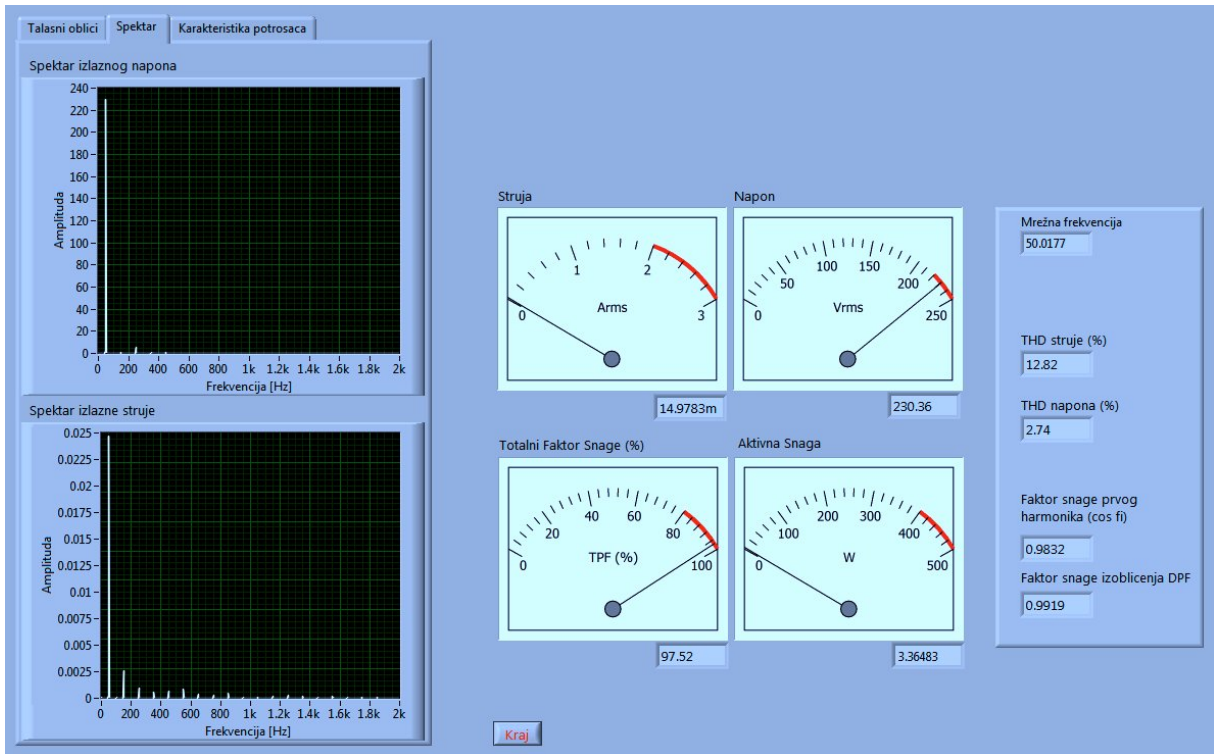

Figure 8. Virtual instrument user interface

User interface also provides controls for data manipulation and saving measured values.

Figure 8. shows measured values for presented voltage converter. Voltage and current power spectrums are shown in panels at the left side of the virtual instrument. The gauge indicators and numeric indicators in the middle of virtual instrument shows RMS value of input current and voltage (in this case 14.97mA and 230.96V), total power factor (97.52) and real power (3.36W). Measured power grid frequency (50.0177Hz), current THD (12.82%), voltage THD (2.74%), displacement power-factor (power factor of the first harmonic, $\cos(\phi)$ is 0.9832), distortion power factor DPF (0.9919) are shown at the right pane. The measurement is performed using 66Ω output load. In this case, output DC voltage is 5.7V and output current is 86mA.

The virtual instrument also shows waveform (Figure 9.) and input voltage/current characteristic.

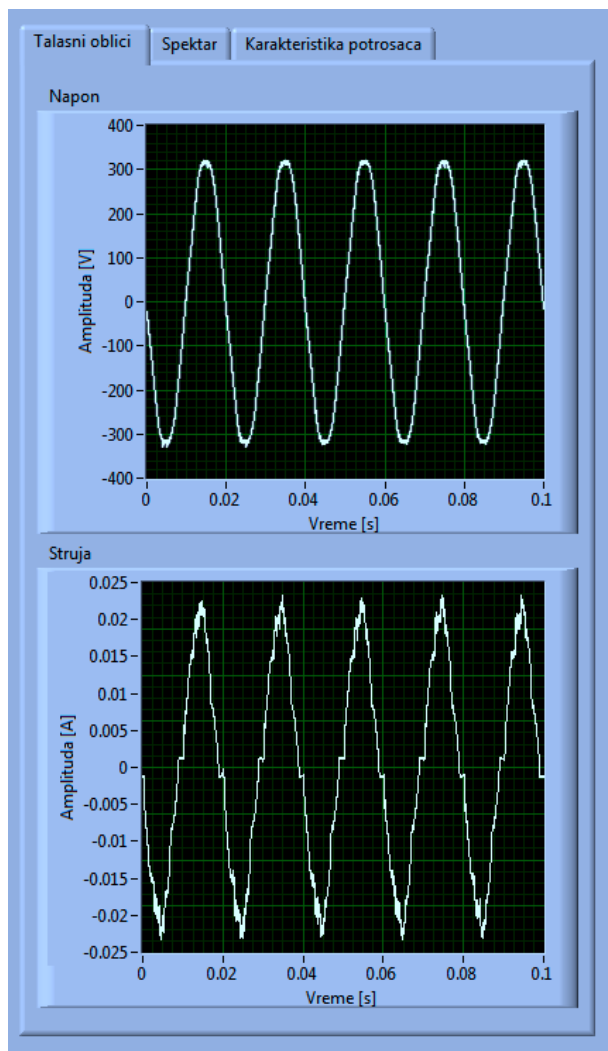

Figure 9. Current and voltage waveforms

4. CONCLUSION

The preliminary results show that power factor and distortions of given power supply concept satisfy the requirements and IEC-1000-3 standard. The measurements are performed for one phase operation.

Table 1 shows measured output voltage and current dependences of input AC voltage.

Startup AC voltage V_{in} [V _{RMS}]	Input AC current I_{in} [mA _{RMS}]	Output DC voltage V_{out} [V]	Output DC current I_{out} [mA]
80	9.5	5.8	50
85	28.5	5.7	170
85 - 200	28.5 - 10.3	5.7	170

Table 1. Output voltage dependences of input voltage

With continual change of input AC voltage from 85V_{RMS} to 200V_{RMS} and output current 170mA, output DC voltage is constant and equal to 5.7V.

Table 2 shows output DC voltage dependences on the load, maintaining input AC voltage on 200V_{RMS}.

Output DC current I_{out} [mA]	Input AC current I_{in} [mA _{RMS}]	Output DC voltage V_{out} [V]
50	3.7	5.8
170	10.3	5.7
340	19.5	5.65
460	26.1	5.55

Table 2. Output voltage dependences of load (output current)

4. REFERENCES

- [1] Dokić, B.: *Power Electronics – transducers and regulators*, Akademska misao, Belgrade, 2007, (in serbian).
- [2] Litovski V., Lazović M.: *Osnovi elektronike*, Niš, 1996.
- [3] Dimitrijević, M., Savić, M., Litovski, V.: *Sistem za merenje faktora snage i izobličenja*, Proc. of the INDEL 2006 Conference, pp. 168-171, Banja Luka, Bosnia and Hercegovina.
- [4] Dimitrijević, M., Litovski, V.: *Power Factor and Distortion Measuring for Small Loads Using USB Acquisition Module*, Proc. of REV2006 Conference, Maribor.
- [5] Dimitrijević M., Litovski V.: *Computer Integrated Analogue Electronics Laboratory for Undergraduate Teaching*, Proceedings of Remote Engineering Virtual Instrumentation Symposium, Brasov, Romania
- [6] Dimitrijević, M., Litovski V.: *Implementation of the Component Characteristic Curve Tracer Using PC-based Acquisition Card*, Proc. of Small System Simulation Symposium 2005, pp. 63-66
- [7] Dimitrijević, M., Litovski V.: *Implementation of 1MHz Scalar Network Analyzer Using PC-based Acquisition Card*, Proc. of 49th Conference of ETRAN, pp. 90-93
- [8] Dimitrijević M.: *Computer Integrated Laboratory for Electronics*, MSc thesis, 2005